

IMRO MAX RECOVERY[®] SYSTEM

Specially designed for a wide moisture range of IBA Recycling plants



Discover more!



Four Main steps for MAX RECOVERY® on fine metals in IBA plants

Recovering rate up to 90%
Purity rate up to 95%



➤ **Step 1**
Conditioner (Desagglomeration)

➤ **Step 2**
Ballistic separator (Remove the fines < 0,4 mm)

➤ **Step 3**
Cascading Non-ferrous separator RCSX F-240 (High frequency NFE separation)

➤ **Step 4**
Non-ferrous Purifying system RCSX D-60 Purifier (Special designed magnet system for fines)

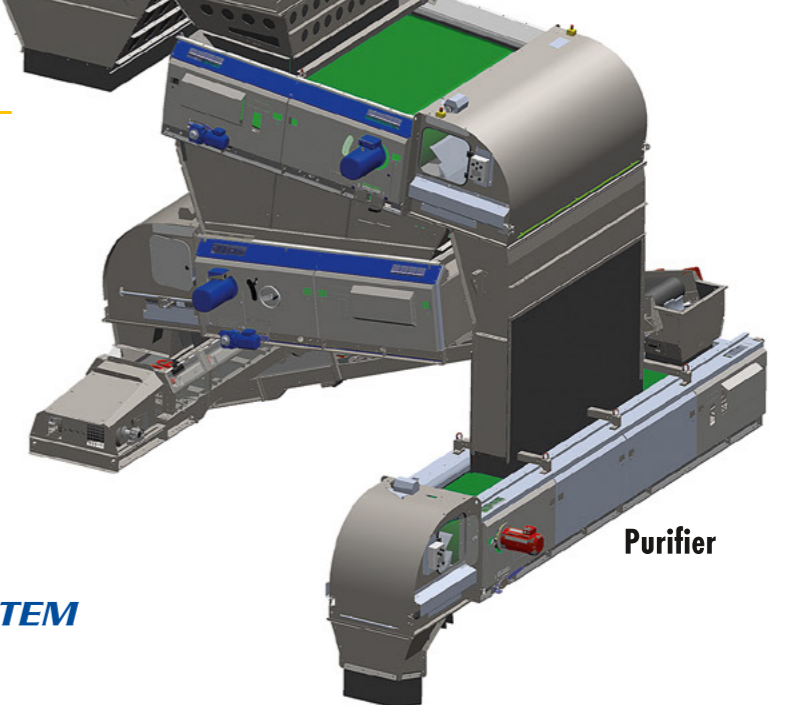



Separation technology



Recycling plants



Conveyor technology

MAX 2024/01

PURE SUCCESS

neumannmaschinenbau.de

IMRO Maschinenbau GmbH
Landwehrstrasse 2 • D-97215 Uffenheim

Phone +49 (0) 98 48 - 97 97-0

Fax +49 (0) 98 48 - 97 97-97

projekte@imro-maschinenbau.de
www.imro-maschinenbau.de



RecycleCraft[®] by IMRO

IMRO
MASCHINENBAU GMBH

Maximum recovery of recyclable materials - IMRO - Europe's separation and conveying experts